

CHAMFERING TOOL

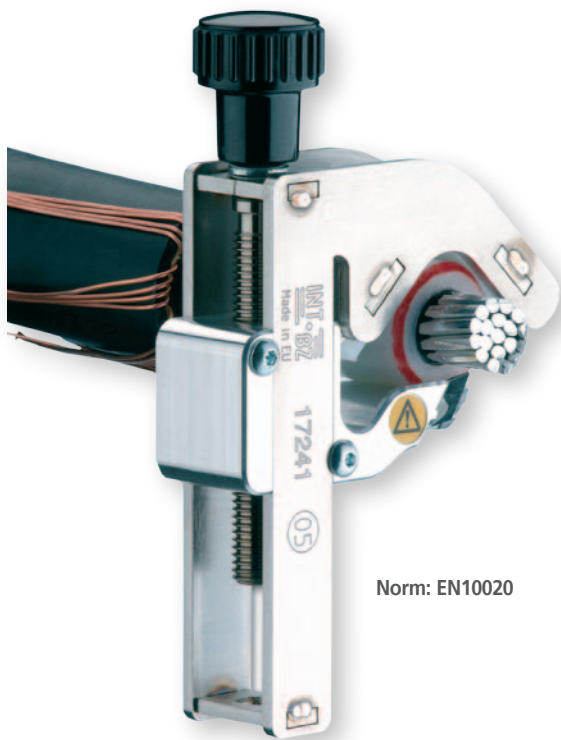

Norm: EN10020

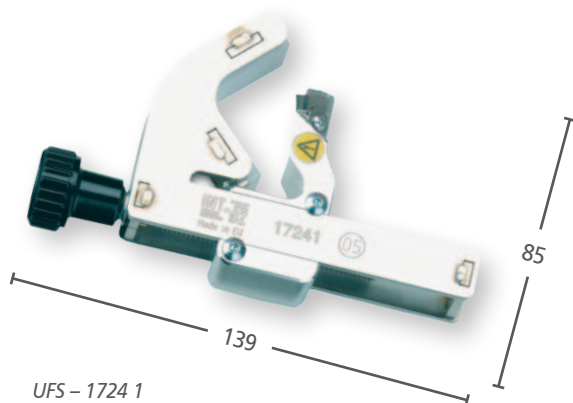

UFS – 1724 1



UFS-Set – 1724 0

UFS – Tool for Chamfering Primary Insulation

APPLICATION RANGE	ø 15 - 60 mm
SUGGESTED APPLICATION	Any type of primary insulation

Technical Characteristics:

- Designed for chamfered cuts of primary insulation of MV cables (2 x 45°)
- Positioning on the cable with a clamp system
- Tool fitted with PTFE plates ensuring optimal sliding on the cable without the use of silicone paste
- Replaceable blade
- Rotation diameter max. 130mm
- This tool is not suitable for pencilling

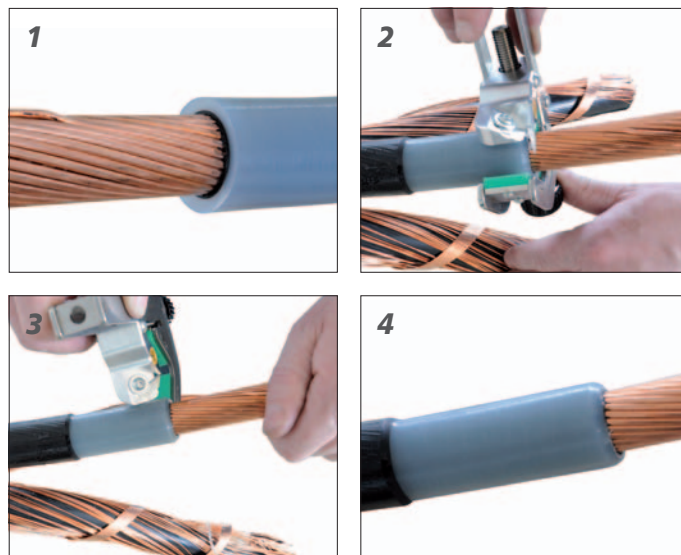

- SMALL SELFROTATING TO WORK ON LIMITED SPACE
- EASY HANDLING THROUGH 1 ADJUSTING KNOB
- UNIVERSAL UP TO 45 kV

Description	Order No.	Dimensions	Weight
Set: UFS	1724 0	170 x 50 x 90 mm	390 g
Spare blade	1724 2	-	-

Attention: not suitable for work under voltage

SET Equipment:

- UFS – tool for chamfered cuts of primary insulation 1724 1
- 2,5mm Allen wrench..... 1710 0
- Soft nylon case AB17130